

Turbo Car

Caution - electrically operated product

Not recommended for children under 8 years of age.

As with all electric products, precautions should be observed during handling and use to prevent electric shock.

PARENTS PLEASE NOTE: IT IS RECOMMENDED THAT THIS TOY BE PERIODICALLY EXAMINED FOR ANY FAULTS AND SHOULD NOT BE USED UNTIL REPAIRS ARE MADE.

POWER PACK RATING: INPUT 240V AC 50Hz

OUTPUT 1.6V DC 350mA

OWNERS MANUAL

IMPORTANT - CLEAN TRACK BEFORE USE.

Due to moisture in the atmosphere, a thin film may build up on the track surface. For optimum performance, it is therefore necessary to clean the track before use. Follow the instructions for maximum enjoyment of your new AURORA AFX set, The closest thing to real racing.

1 CAUTION

- Always clean the track before you start racing. Use the track pad provided, an eraser or coin to clean the track rails. Wipe away residue with a clean dry cloth.
- Blow out any deposits that may have fallen into the track grooves.
- **NEVER** use Steel Wool to clean the track.

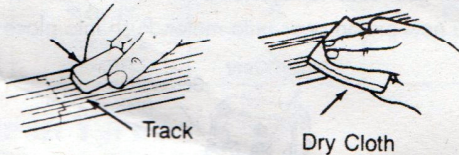

- ### 2
- Choose a layout from the layout sheet.

- ### 3
- Assemble the straight or curved track on a flat, clean surface. Do not assemble track on carpet.
 - Push the pieces of track together until they lock into place.
 - Assemble pieces of track to form the layout of your choice.

- ### 4
- Attach a guardrail to each curve section by placing the guardrail tabs under the track, then snapping up into place.

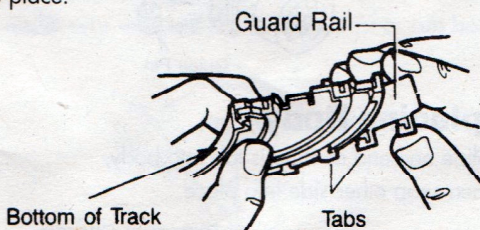

- ### 5
- Snap the trestles together as shown.
 - Attach the trestles to track as needed.

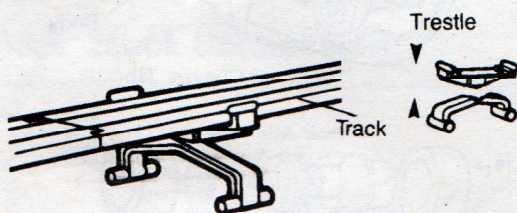

- ### 6
- The 2-way racing plug allows you to change the direction of travel! Flip the plug over to reverse racing direction.

For the latest information visit: www.afxrcing.com.au

- ### 7
- Slide the accelerators plugs into the terminal track.
 - Slide the power packs 2-way racing plug into the terminal track as shown.
 - Plug the power pack into an electrical wall outlet (240 volts)
 - If the external flexible cable of the transformer is damaged, it shall be repaired or replaced by the manufacturer or his service agent or a similar qualified person in order to avoid a hazard.

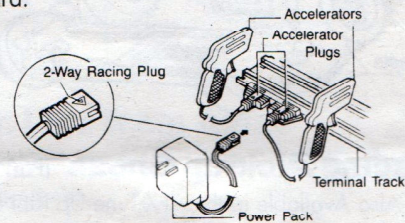

- ### 8
- Place cars on track. Make sure guide pin fits into slot on track.

N.B: OPERATE ONLY ONE CAR PER LANE.

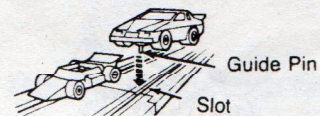

- ### 9
- Squeeze the trigger on the accelerator to make the car accelerate. The more you squeeze the trigger, the faster the car runs!
 - To reduce speed, simply decrease pressure on the trigger.
 - Releasing the trigger stops the car.

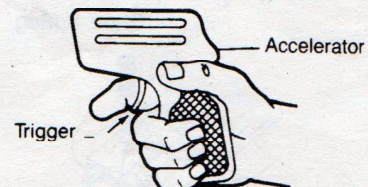

- ### 10
- Pull the pieces apart to disassemble.



- ### 11
- Always disconnect power pack when not in use. Never pull on wires. Always remove connections by pulling the plug.

- Place cars on Track. Make sure Guide Pin fits into Slot on Track.

NOTE: Operate only one car per lane.

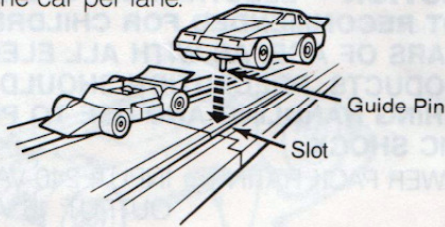

If you've made it this far, you've passed the test and you're ready to race! Here's a handy Troubleshooting Chart in case you run into any problems. As your Pit Crew Chief, I'd like to formally welcome you to the closest thing to real racing!



- Squeeze the Trigger on the Controller to make the car accelerate. The more you squeeze the trigger, the faster the car runs!
- To reduce speed, simply decrease pressure on the Trigger.
- Releasing the Trigger stops the car.

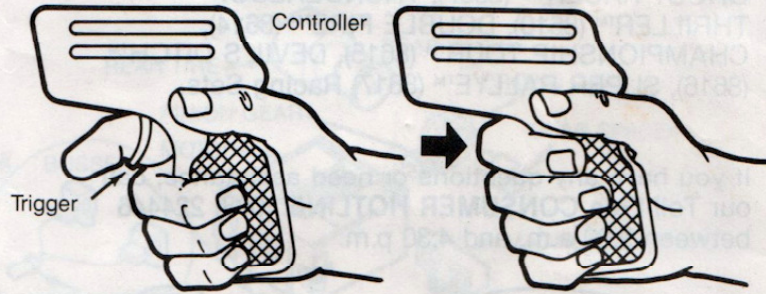

TROUBLESHOOTING CHART

Refer to the Troubleshooting Chart below for your particular problem, then look for Diagrams A through F for the best solution.

	A.	B.	C.	D.	E.	F.
PROBLEM	Dirty Track & Tires	Wheels Rub Chassis	Poor Track Connection	Dirty Cars	Dirty Worn Pick-up Shoes	Wheel & Body Interference
Cars Won't Run	•	•	•		•	•
Cars Hesitate	•		•	•	•	
Cars Squeak/Run Noisy		•				•
Cars Run Slowly/Overheat	•	•		•	•	•
Excessive Spin-outs	•					

A CLEAN TIRES & TRACK

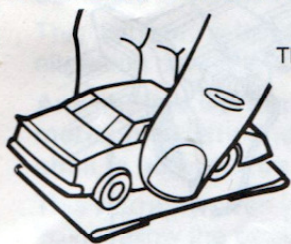

TIRES

Place a strip of cellophane tape on a table as shown. Roll rear tires across the tape a few times.

TRACK

Use an Eraser to clean all Track Rails. Wipe away residue with a clean dry cloth. You can also lay the special Track Pad provided or a coin flat on the Rails and rub until Rails are shiny. Blow into the grooves to remove any small particles. Periodically wipe tracks with a clean cloth to remove excess dust.

B ADJUST WHEELS

If the wheels bind against the car's chassis, use a screwdriver to carefully pry the wheels out.

NOTE: Make sure wheels do not extend past or rub body.

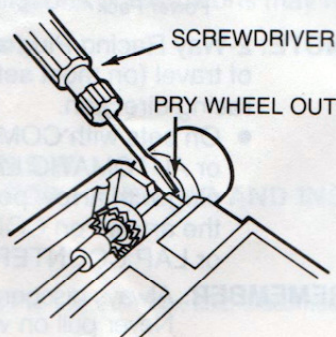

C POOR TRACK CONNECTION

Check to make sure all Track sections are properly connected.

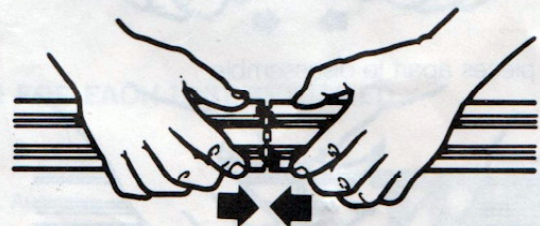

D CLEAN LINT FROM AXLES

Use a toothpick to remove excess lint, dirt, and dust from around the axles.

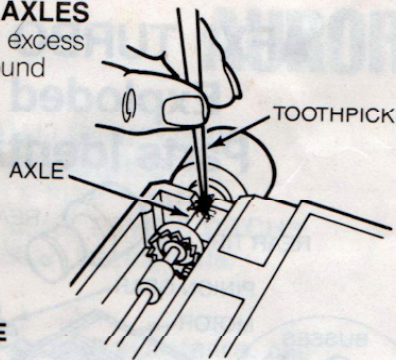

E CLEAN OR REPLACE PICK-UP SHOES

Regularly clean Pick-Up Shoes by carefully rubbing them with a clean pencil eraser or special Track Pad provided.

Do not apply too much pressure or you may bend the Pick-Up Shoes. Do not use steel wool to clean shoes.

If Pick-Up Shoes are slightly or unevenly worn, switch them around.

After excessive wear, you should replace Pick-Up Shoes. See section "Performing a Tune-Up" on how to replace worn-out Pick-Up Shoes.

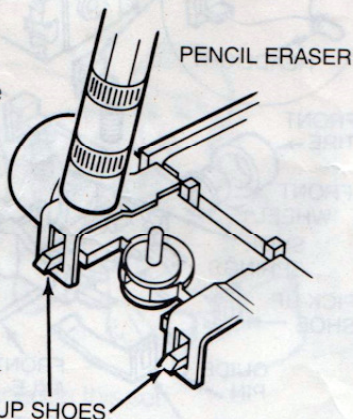

B. REPLACING PICK-UP SHOES

1. Carefully pull Pick-Up Shoe forward.
2. Lift up Shoe and remove.
3. Replace with new Shoes.

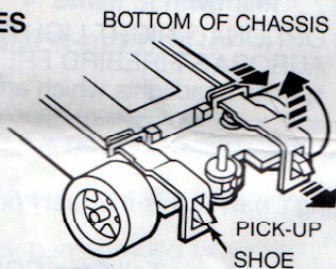

C. REPLACING SHOE SPRINGS

1. After removing Pick-Up Shoes (see "REPLACING PICK-UP SHOES" above), replace Springs as shown.

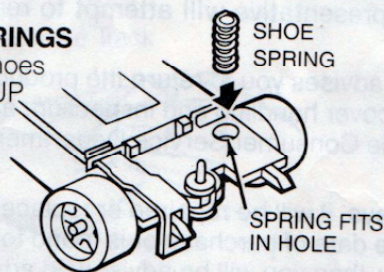

D. REPLACING REAR AXLE ASSEMBLY

1. In the AFX Tune-Up Kit, the Rear Axle comes assembled with Gear Spacer and Crown Gear already in place. Simply snap Rear Wheel Assembly in as shown, then slide Tires onto Wheels.

NOTE: You may need to adjust the Wheels: see "Troubleshooting" Section B.

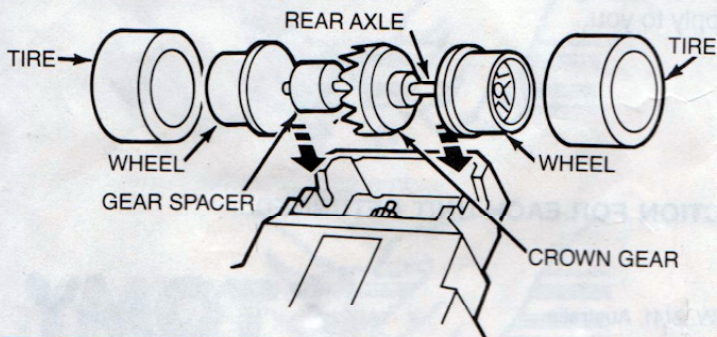

F REALIGN CHASSIS

Occasionally, the car's snap-on body may shift, causing the tire to rub against the body. Hold the car upside-down and center the chassis until it snaps back into position.

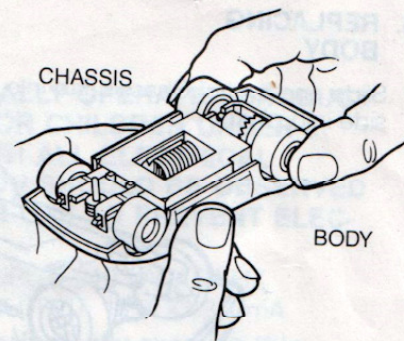

PERFORMING A TUNE-UP

To keep your car running in top performance, here's the mechanics guide to AFX tune-ups. A pair of spare shoes and springs are included. Ask your Toy or Hobby Dealer for the AURORA Tune-Up Kit (No. 8634) which includes all the parts you need for a complete tune-up.

NOTE: Before you begin, place a piece of white paper under your work area to make pieces easier to find.

A. REMOVING BODY

1. Hold Rear Wheels. Pull out on one side of Body until it clears the Chassis Tab, then remove Body.

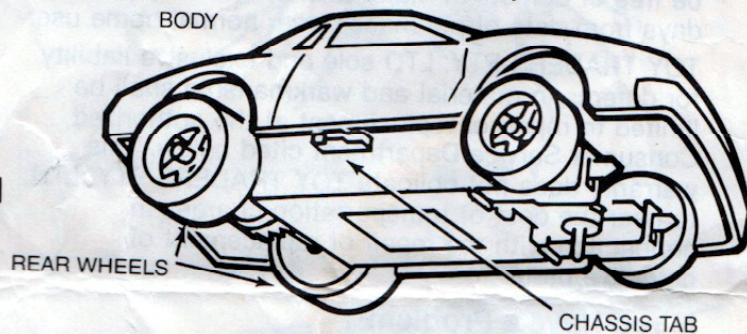

E. REPLACING PINION GEAR

NOTE: Rear Axle must first be removed before replacing Pinion Gear. See section above "REPLACING REAR AXLE ASSEMBLY" for instructions.

1. Insert small screwdriver blade as shown and push Pinion Gear rearward to remove.
2. Slide new Pinion Gear onto Motor. Push into place.

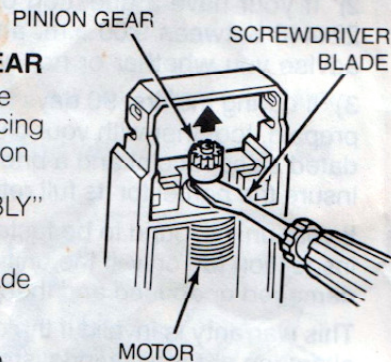

F. REPLACING GUIDE PIN

1. Simply push Guide Pin out of Slot and replace with a new Guide Pin (available in AURORA Tune-Up Kit No. 8634).
2. Guide Pin slides and snaps into place.

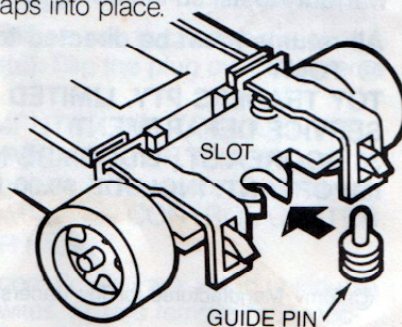

Limited lifetime warranty

TOY TRADERS (Sales) Pty Ltd, the sole Australian agent, warrants to the original consumer purchaser of its AURORA AFX Racing Sets that the product will be free of defects in material or workmanship.

TOY TRADERS (Sales) Pty Ltd sole and exclusive liability for defects in material and workmanship shall be limited to repair or replacement at the authorised Consumer Service Department cited below.

THIS WARRANTY DOES NOT COVER:

1. Normal wear and tear
2. Damage caused by mishandling or abuse
3. Damage due to incorrect maintenance
4. Globes

If you have a problem:

1. If your set fails to operate properly, check the troubleshooting chart in this manual and follow the directions for the solution indicated.
2. If you have a question or a problem that you cannot solve, call our **toll free consumer hotline on (1800) 224 446**, or if in the **Sydney area (02) on 9749 1733**, between 9.00 am and 4.30 pm Eastern Time. Monday to Friday only. A representative will attempt to remedy the problem and advise you whether or not a warranty service is required.

If your unit is found to be factory defective, it will be repaired or replaced **free of charge**.

This warranty is invalid if the damage or defect is caused by normal wear and tear, act of God, consumer abuse, unauthorised alteration or repair, vandalism, or misuse.

Any implied warranties arising out of the sale of the product, including the implied warranties of merchantability and fitness of a particular purpose, are limited to defects in material or workmanship. TOMY CORP. and TOY TRADERS (Sales) Pty Ltd shall in no event be liable for incidental, consequential, contingent, or any other damages.

All returns must be directed to:

TOY TRADERS (SALES) Pty Ltd.
Service Department
36-38 Boorea Street
(P.O. BOX 232)
Lidcombe, NSW 2141

TOMY, Manufactured for Toy Traders (Sales) Pty Ltd, P.O. Box 232, Lidcombe, NSW 2141, Australia.

AFX® Turbo Car Chassis exploded view – parts identification

* OPTIONAL: NIGHT LIGHTED CARS (as featured in Aurora AFX Fireball Challenge Race Set No 5552) have special headlights which are soldered to Busses as shown.

** For better handling and wall climbing optional power magnet is available separately (FX016).

